

# 19436

(D)	MONTAGEANLEITUNG:	DREHTÜR 1-TLG. + SEITENWAND IN FLUCHT + SEITENWAND IM WINKEL
(GB)	INSTALLATION INSTRUCTIONS:	HINGED DOOR + IN LINE FIXED PANEL + FIXED PANEL IN 90°
(F)	NOTICE DE MONTAGE:	PORTE PIVOTANTE + PAROI FIXE EN LIGNE + PAROI FIXE
(CZ)	NÁVOD K MONTÁŽI:	OTOČNÉ DVEŘE + BOČNÍ STĚNA V ROVINĚ + BOČNÍ STĚNA 90°
(PL)	INSTRUKCJA MONTAŻU:	DRZWI OBROTOWE + ŚCIANKA BOCZNA W LINIE + ŚCIANKA BOCZNA 90°
(SK)	NÁVOD NA MONTÁŽ:	JEDNOKRÍDLOVÉ DVEŘE + PEVNÁ STĚNA + VOČNÁ STĚNA 90°
(RU)	ИНСТРУКЦИЯ ПО МОНТАЖУ:	РАСПАШНАЯ ДВЕРЬ С ПАНЕЛЬЮ В ОДНОЙ ЛИНИИ
(E)	INSTRUCCIONES DE MONTAJE:	PUERTA + FIJO EN LÍNEA + FIJO A 90°
(RO)	INSTRUCȚIUNI DE MONTAJ:	UȘĂ PIVOTANTĂ DINTR-O BUCATĂ + PARTE FIXĂ ÎN CONTINUARE+ PERETE LATERAL PE COLȚ

1. - 11.

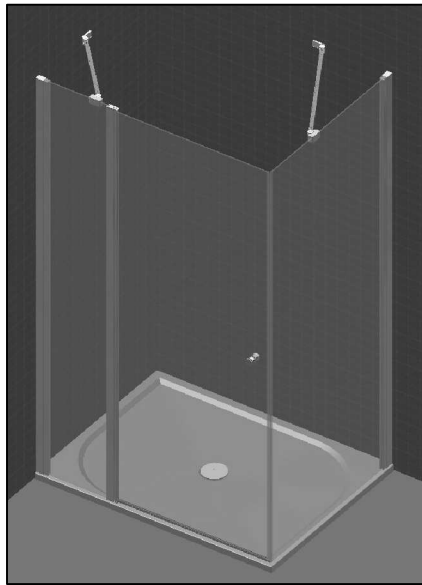

12. - 18.

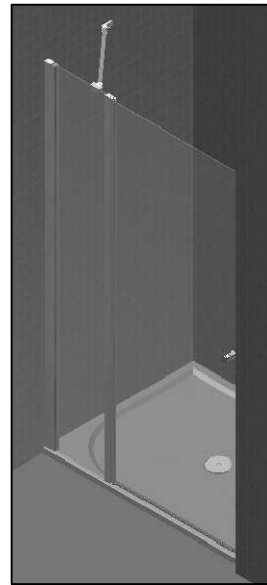

Benötigtes Werkzeug:  
Necessary tools:  
Outil Nécessaire:  
Nářadí potřebné pro montáž:  
Potrzebne narzędzia:  
Potrebne náradie:  
необходимые инструменты:  
Herramientas necesarias:

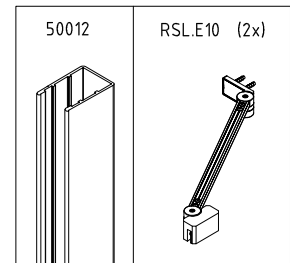
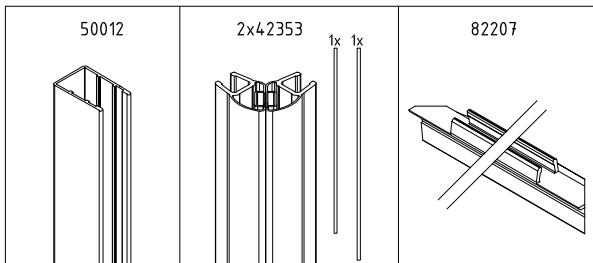
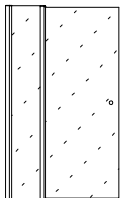
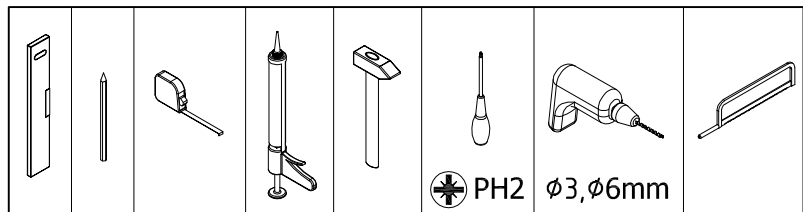
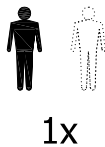

Zubehör:  
Equipment:  
Accessoires:  
Příslušenství:  
Dodatki:  
Príslušenstvo:  
Аксессуары:  
Accesorios:

	 1 x 51399	 1 x 51339	 3 x 14139 4.2 x 50mm	 3 x 14003 3.5x9,5mm	 3x51337	 MT0233
			 3 x 16000 $\phi 6\text{mm}$	 1 x 11221	 3x51338	
	 1 x 51399	 1 x 51399	 3 x 14139 4.2 x 50mm	 3 x 14003 3.5x9,5mm	 3x51337	
			 3 x 16000 $\phi 6\text{mm}$		 3x51338	

1.

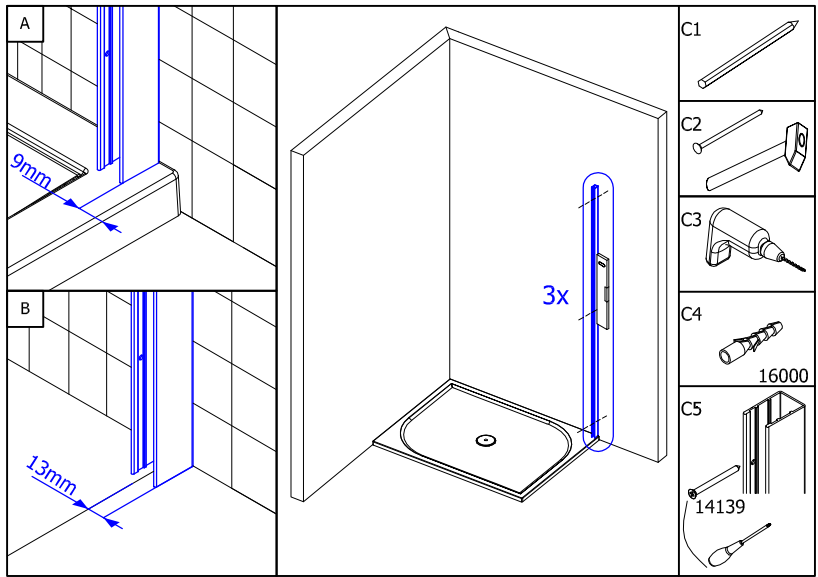
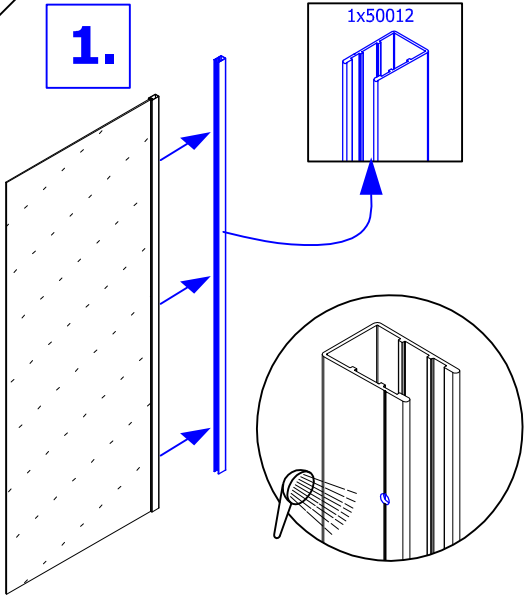

2.

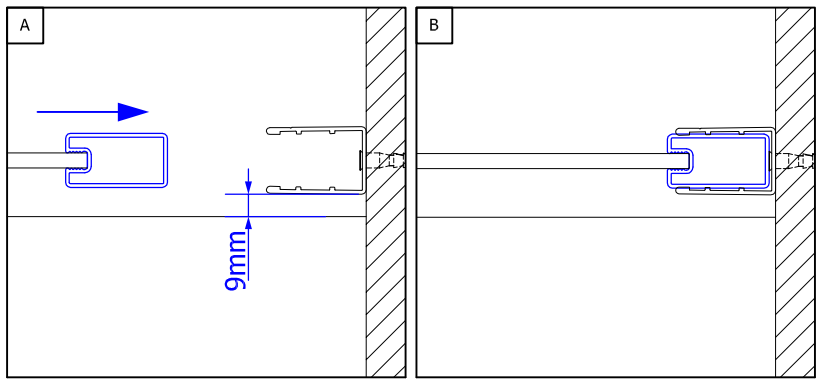
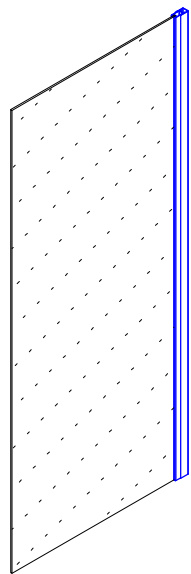

3.

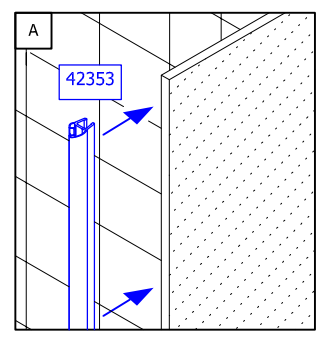
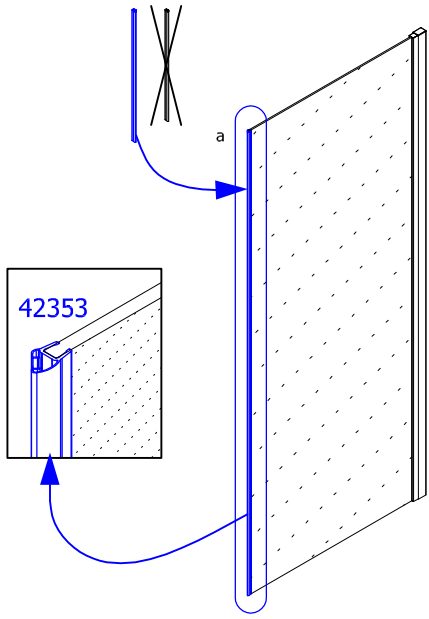
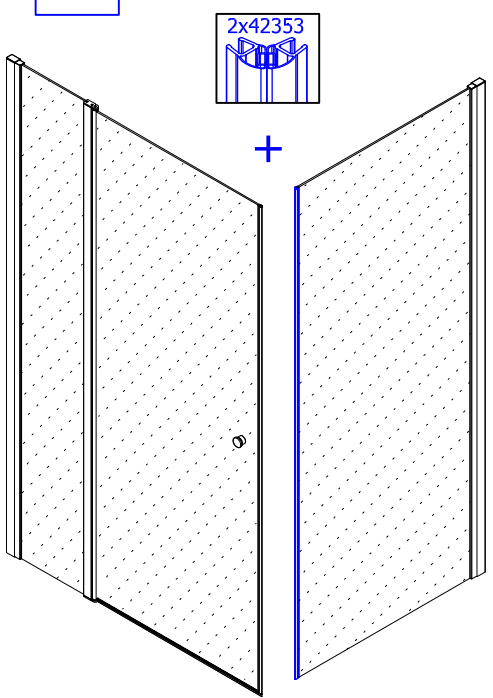

4.

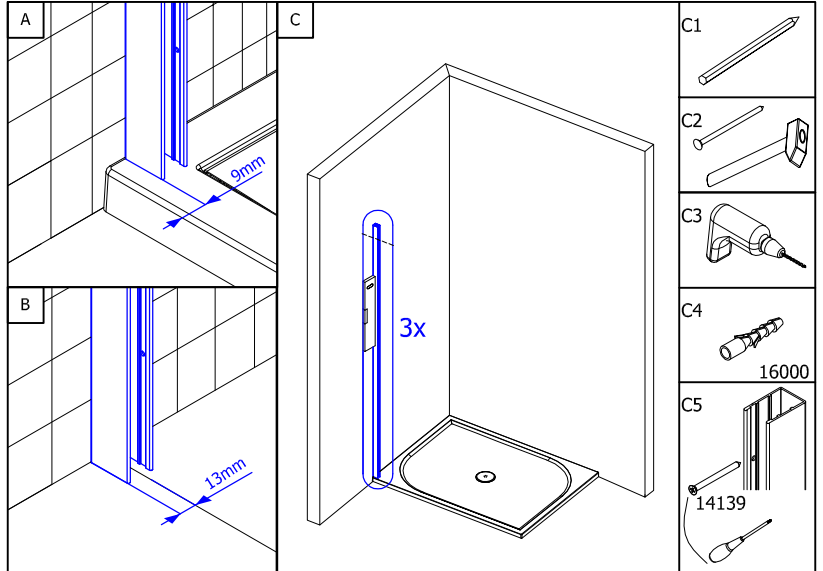
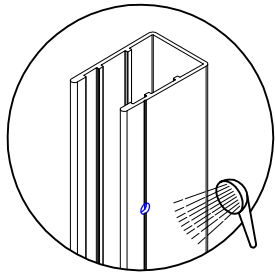
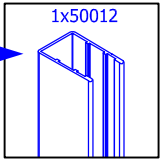

5.

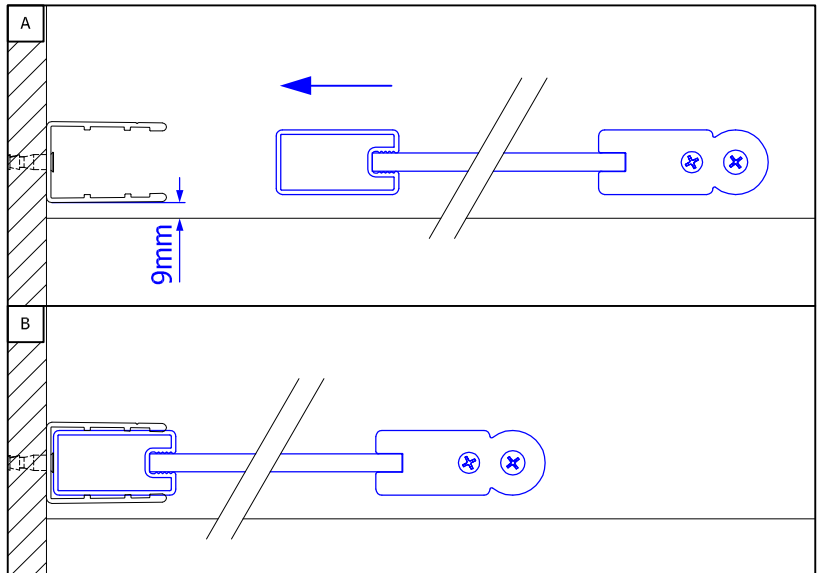
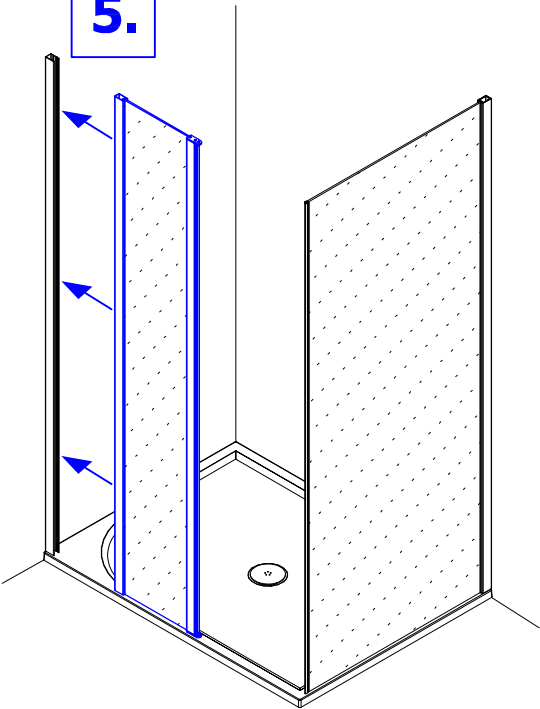

6.

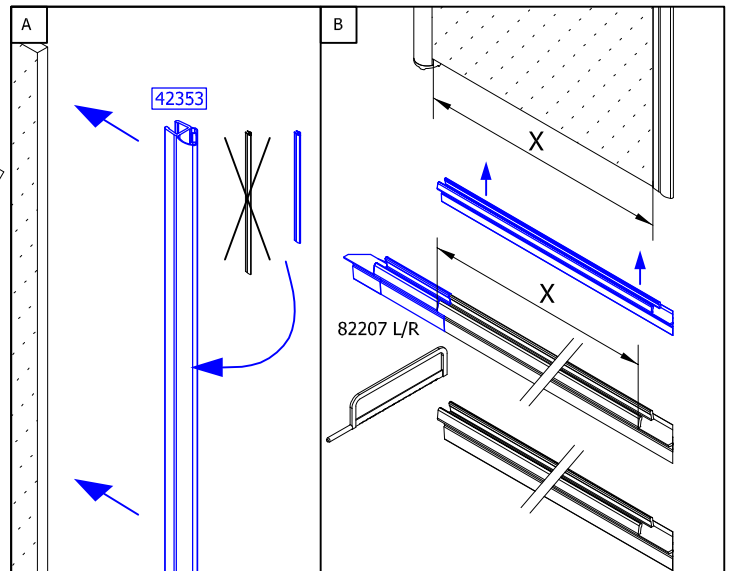
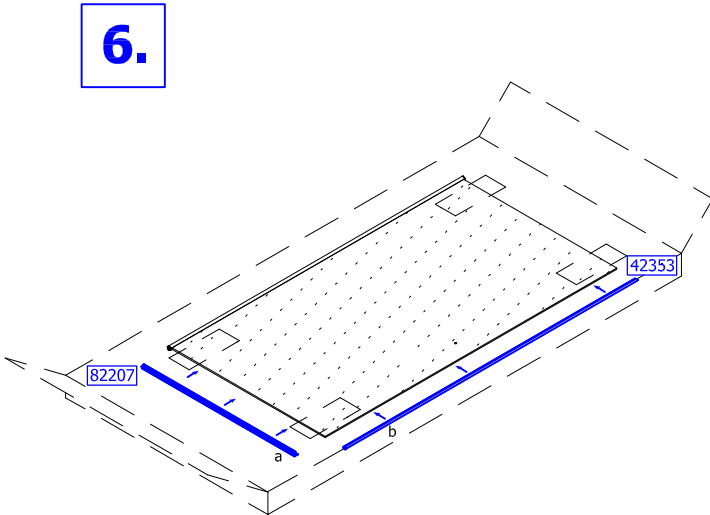

**7.**

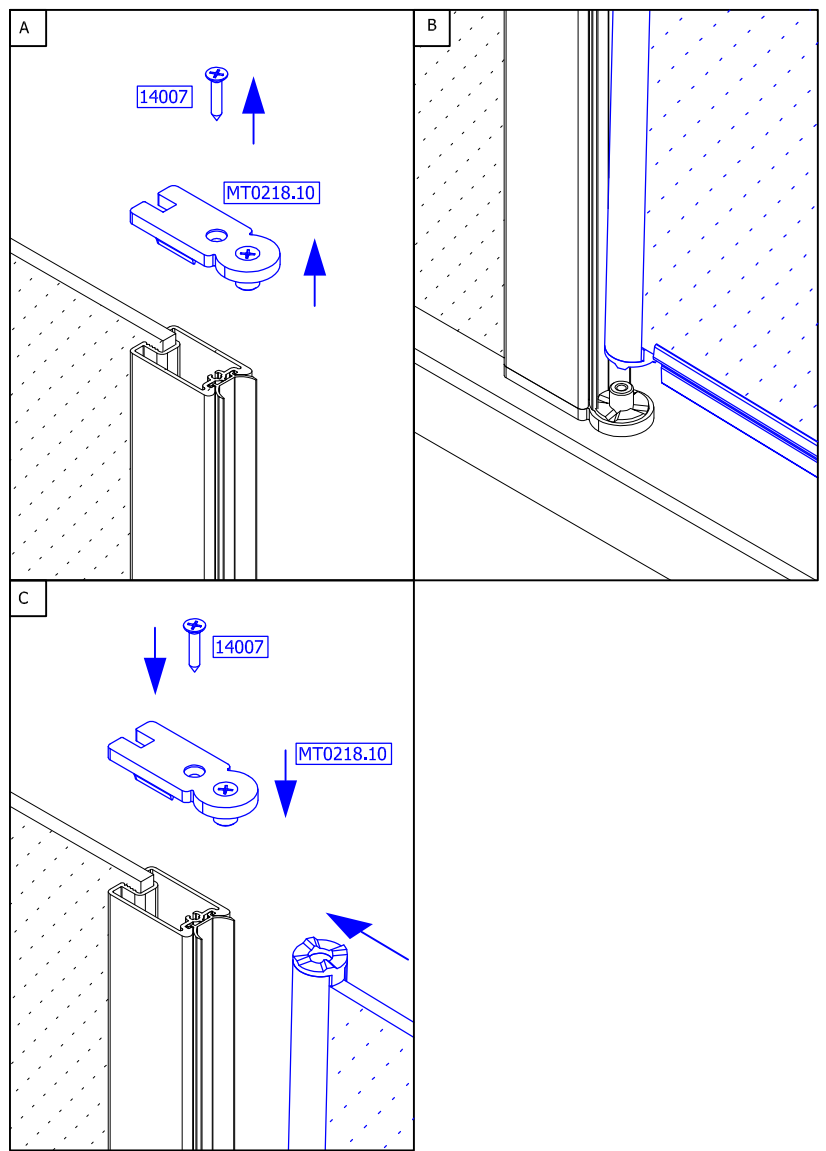
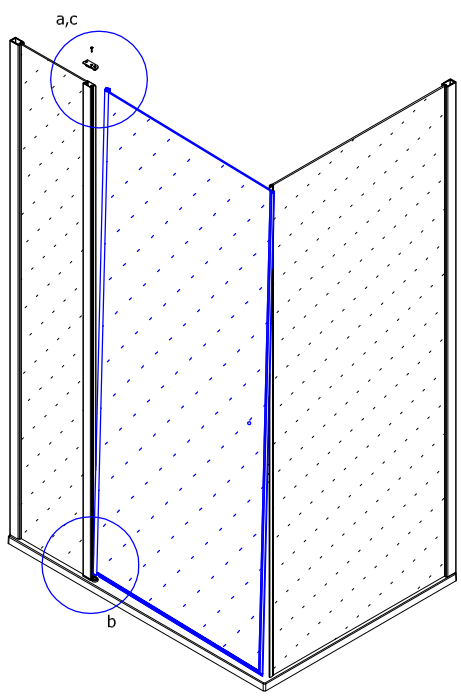

**8.**

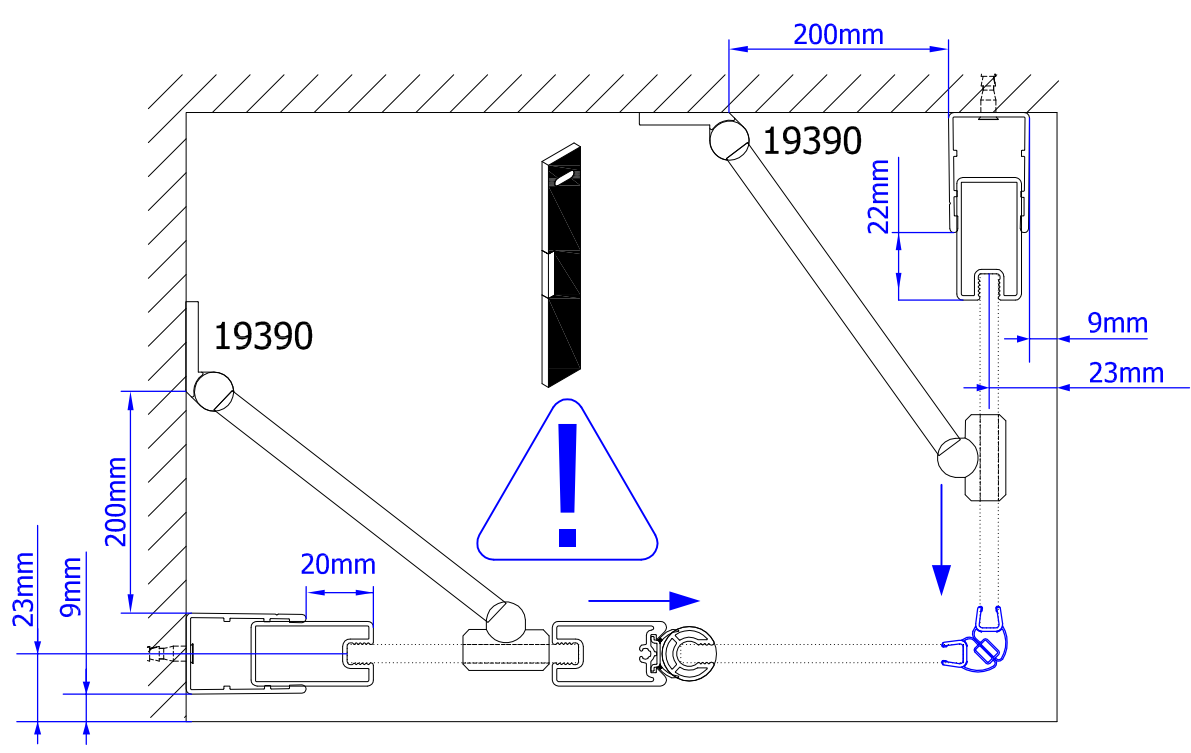

**9.**

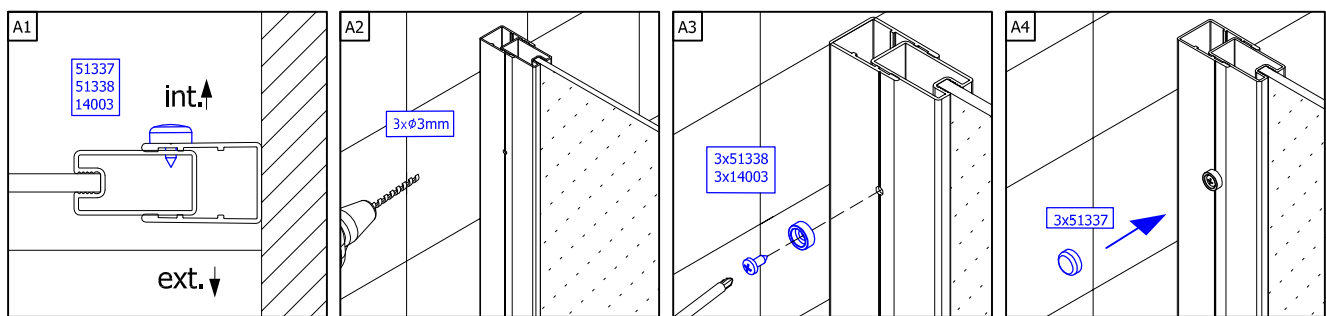
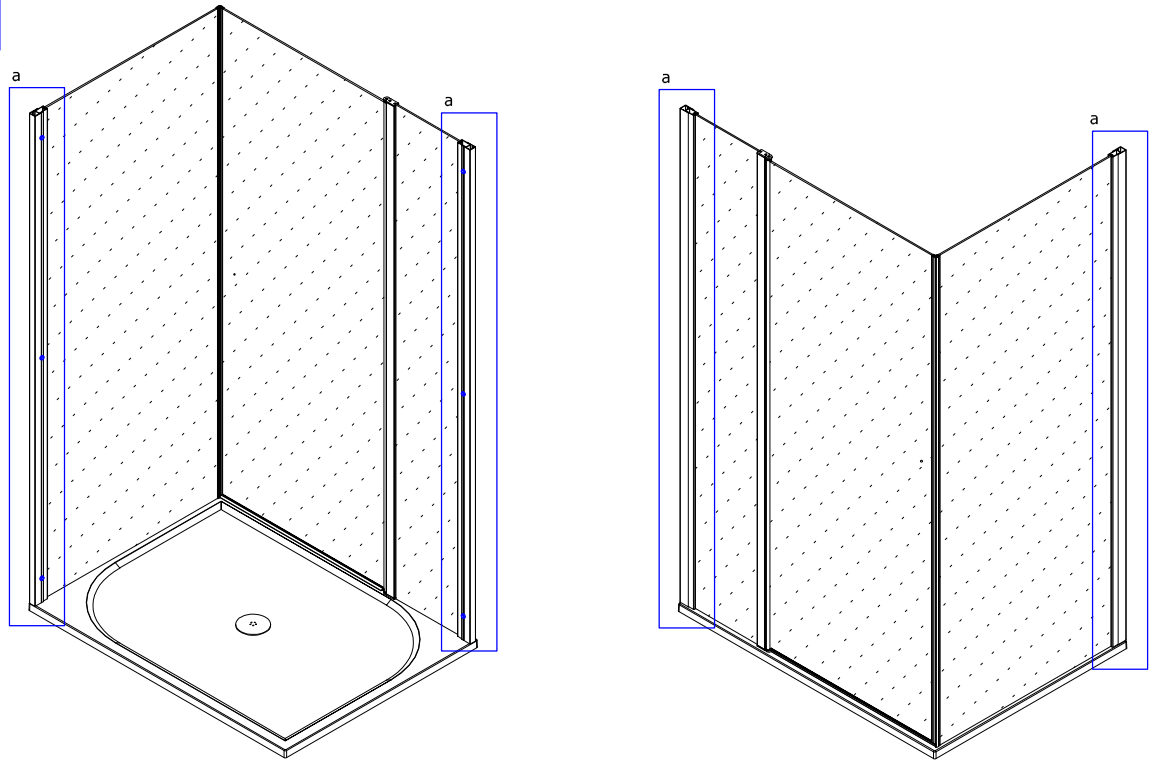

**10.**

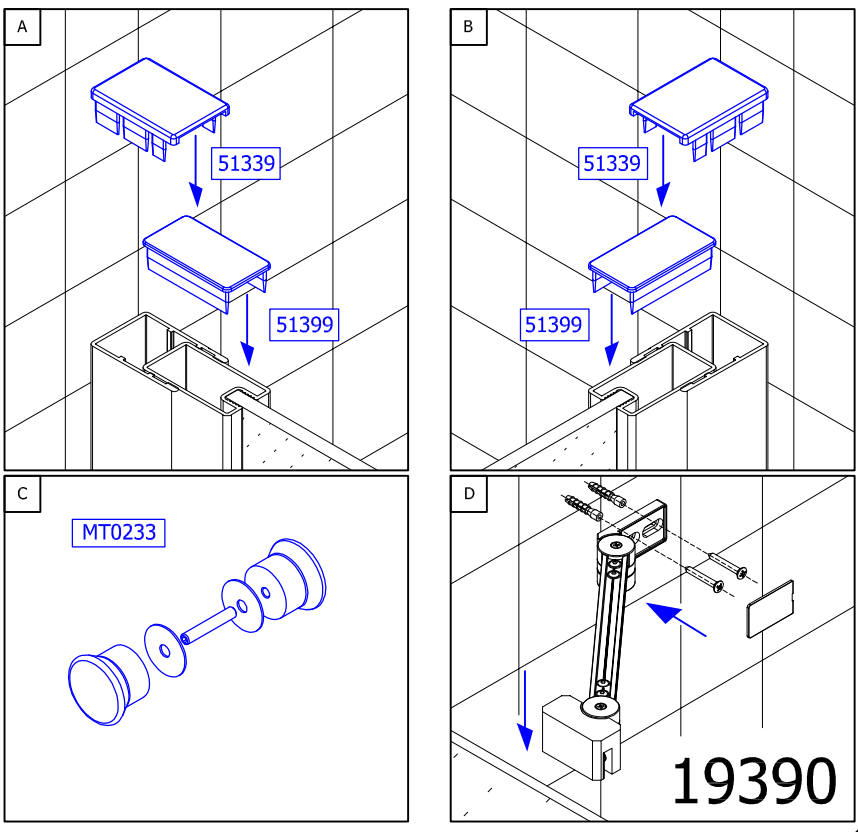
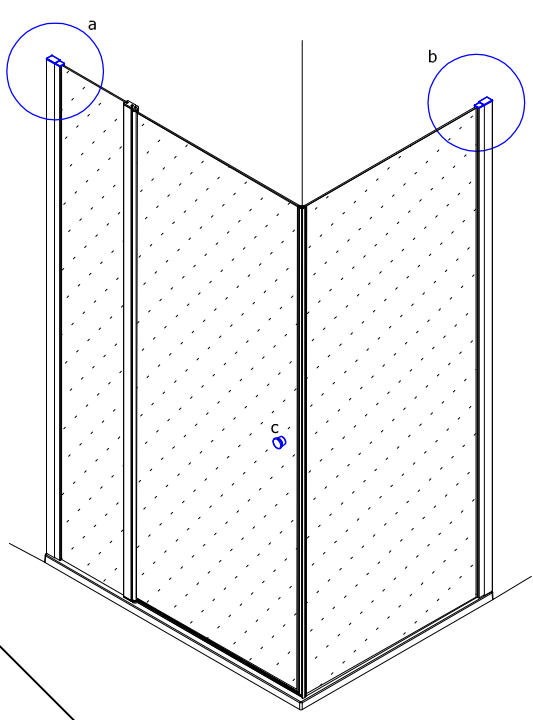

11.

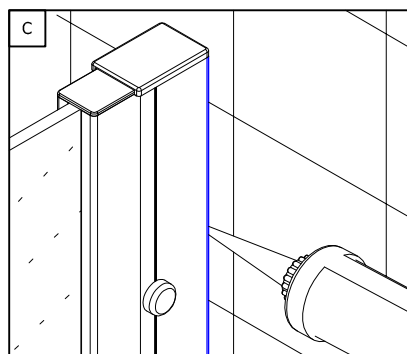
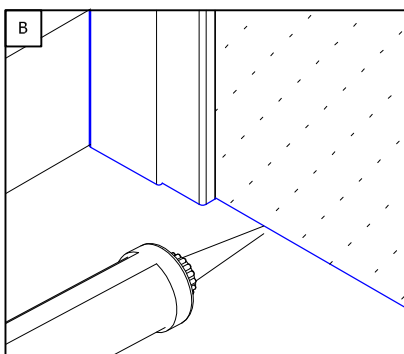
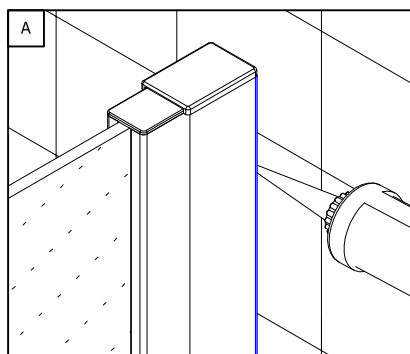
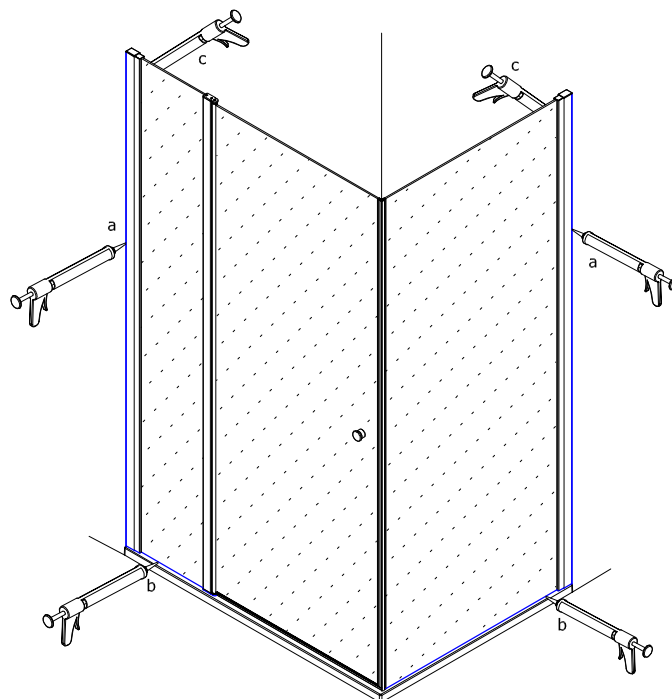

**Achtung!** Nur Sanitär-Silikon - bakterizid und fungizid eingestellt verwenden.

**Caution!** Use only bactericidal and fungicide sanitary silicone.

**Attention!** N'utiliser que du silicone sanitaire bactéricide et fongicide.

**Pozor!** Používejte pouze baktericidní a fungicidní sanitární silikon.

**Uwaga!** Stosować tylko silikon sanitarny - bakterio i grzybobójczy.

**Pozor!** Užívajte pouze baktericidný a fungicidný sanitárny silikón.

**Внимание!** Применяйте только антибактериальные силиконовые герметики с фунгицидом

**Cuidado!** Utilizar solamente silicona sanitaria bactericida y fungicida.

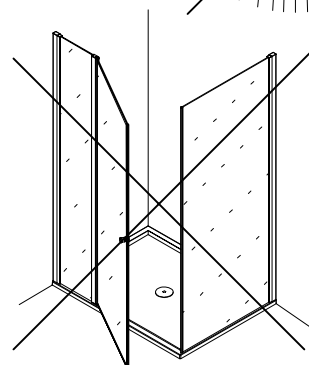
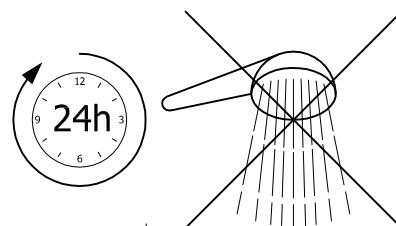

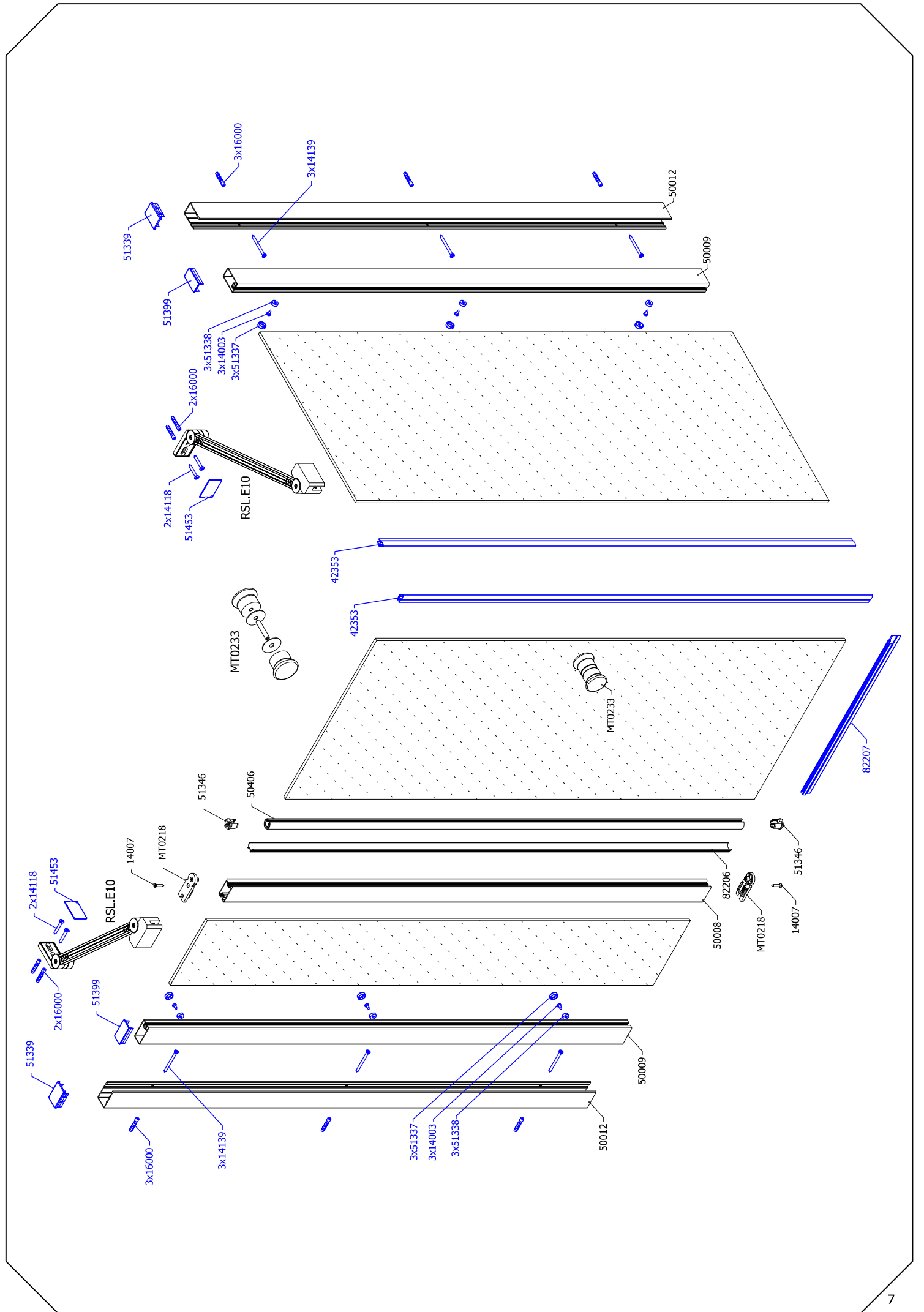

Benötigtes Werkzeug:  
 Necessary tools:  
 Outil Nécessaire:  
 Nářadí potřebné pro montáž:  
 Potrzebne narzędzia:  
 Potrebne náradie:  
 необходимые инструменты:  
 Herramientas necesarias:

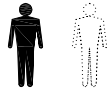

1x

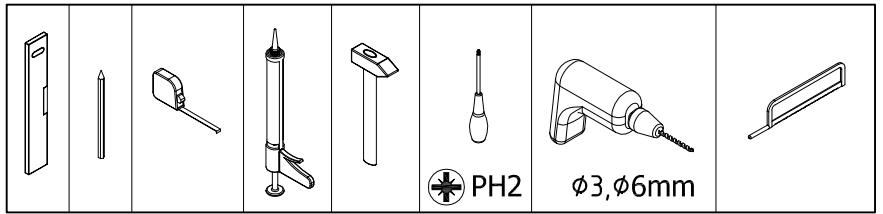

PH2

Ø3, Ø6mm

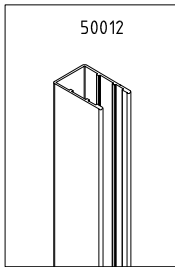
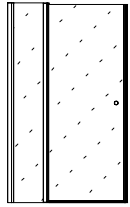

50012

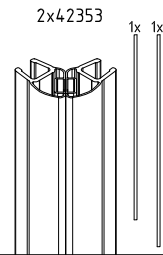

2x42353

1x 1x

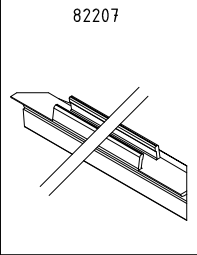

82207

Zubehör:  
 Equipment:  
 Accessoires:  
 Příslušenství:  
 Dodatki:  
 Príslušenstvo:  
 Аксессуары:  
 Accesorios:

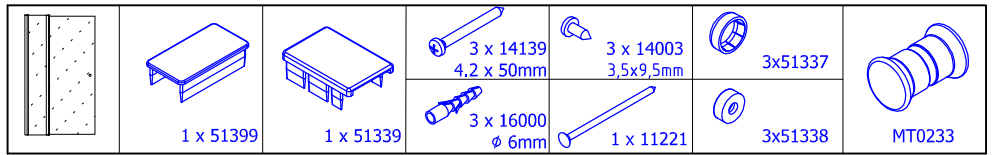

1 x 51399

1 x 51339

3 x 14139  
4,2 x 50mm

3 x 14003  
3,5 x 9,5mm

3x51337

3 x 16000  
Ø 6mm

1 x 11221

3x51338

MT0233

12.

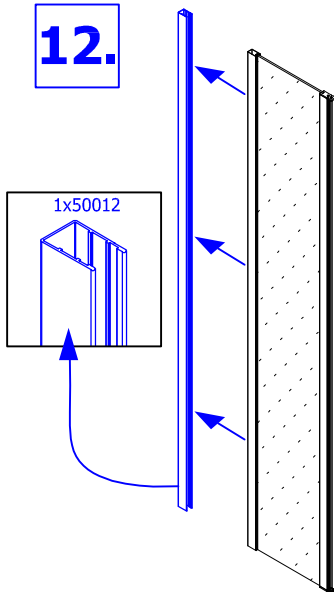

1x50012

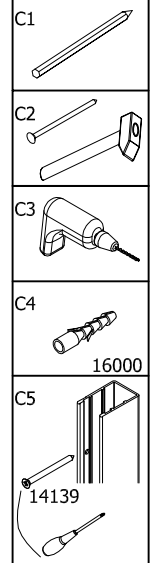
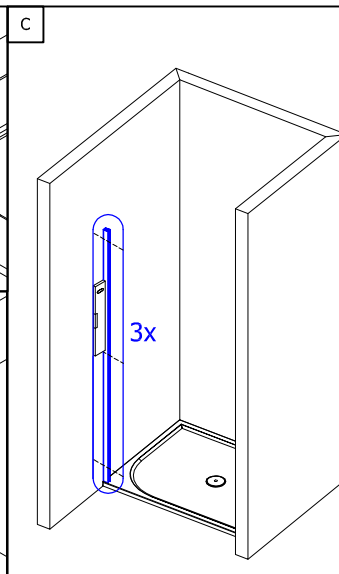
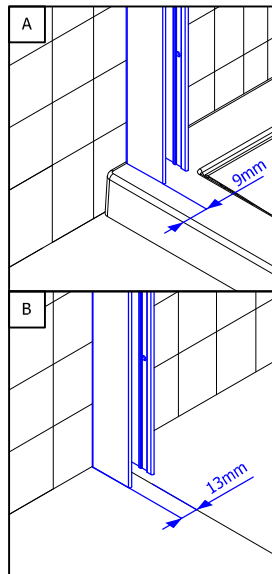

13.

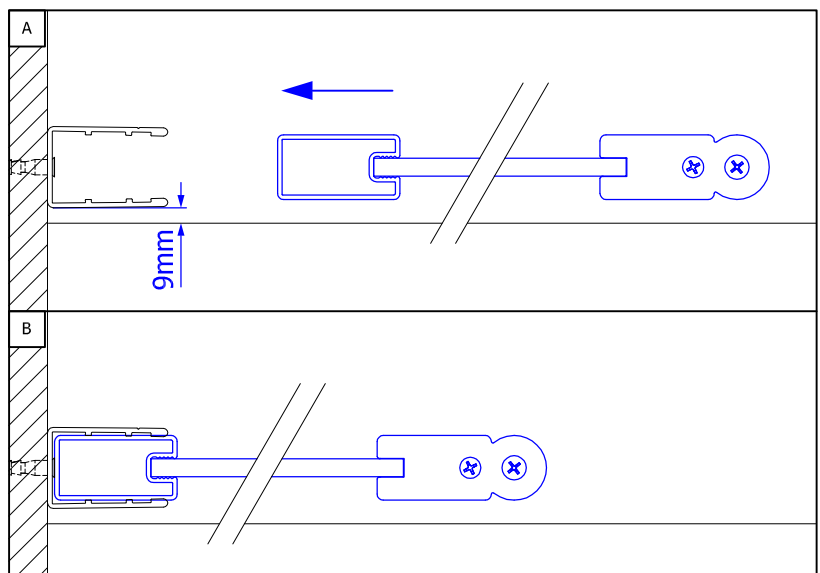
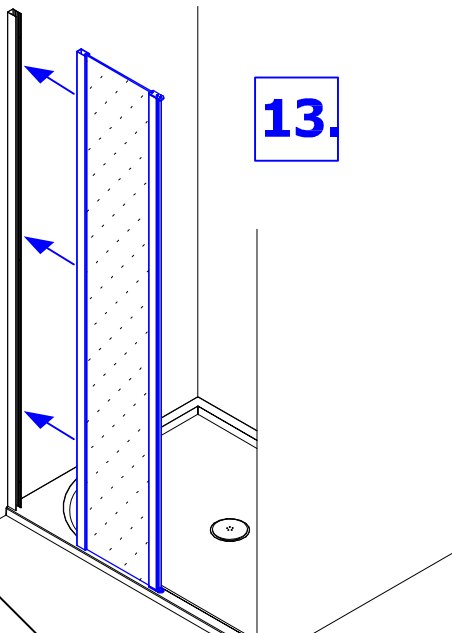



14.

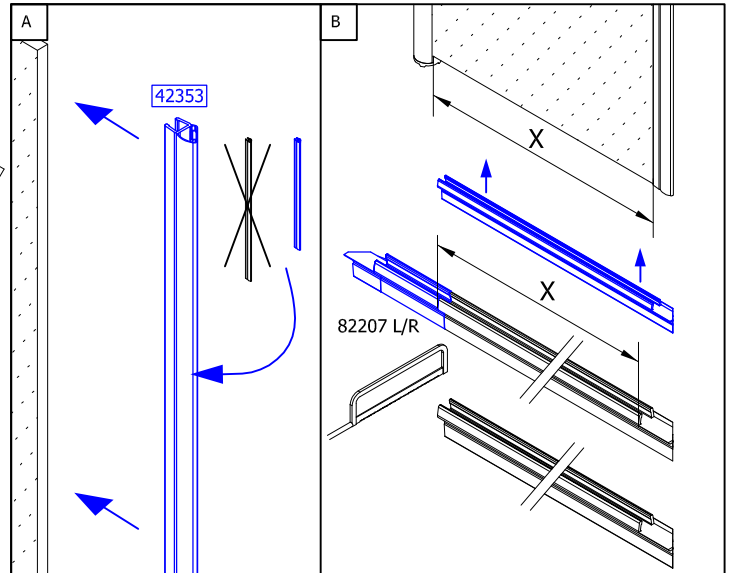
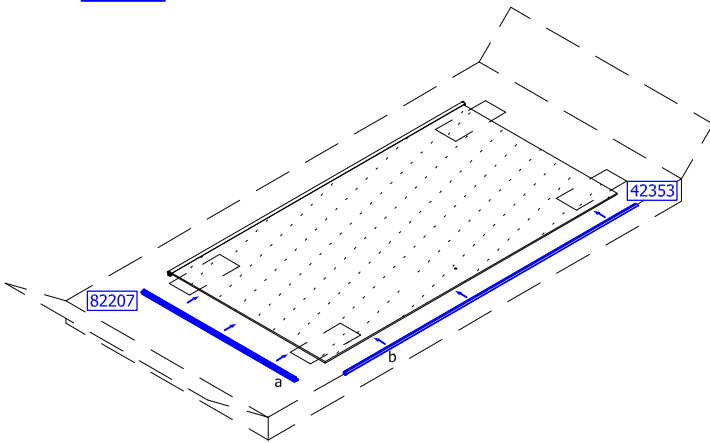

15.

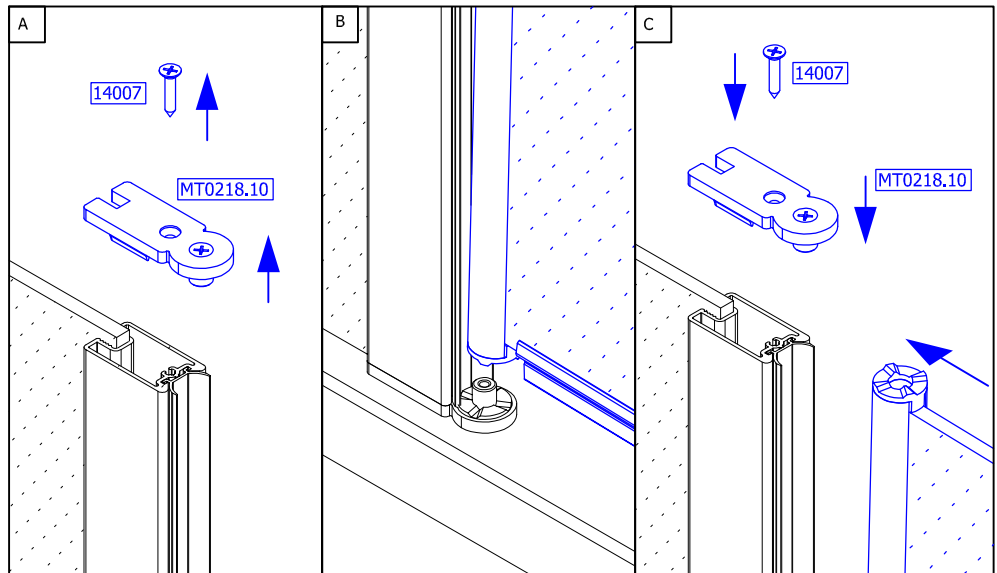
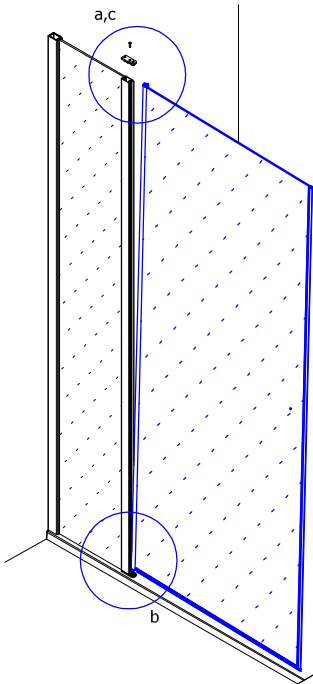

16.

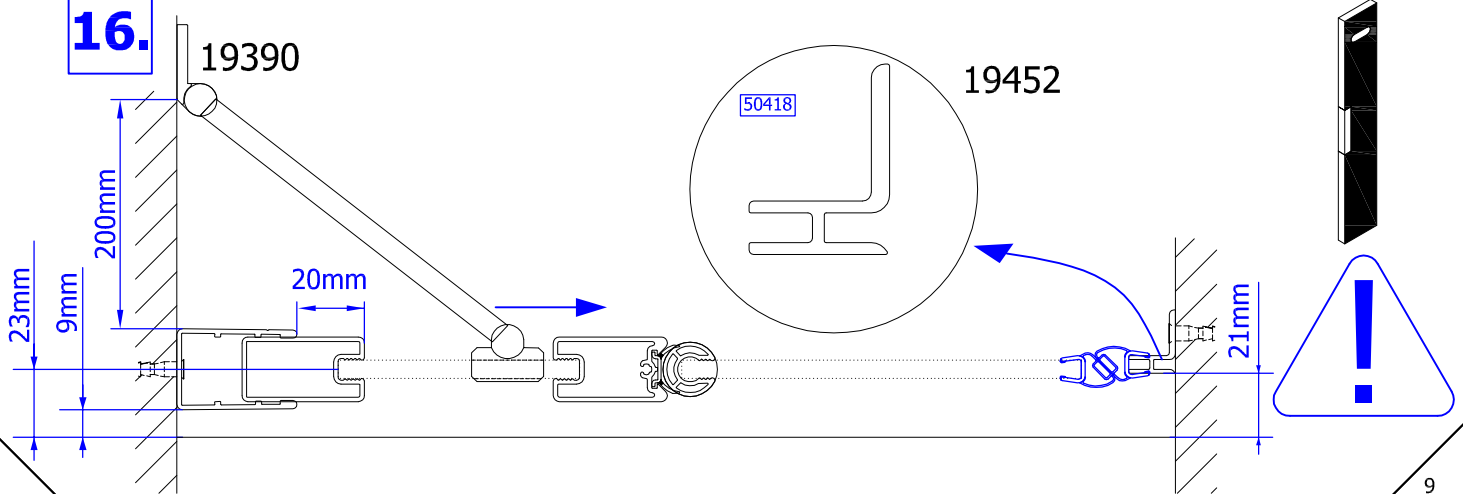

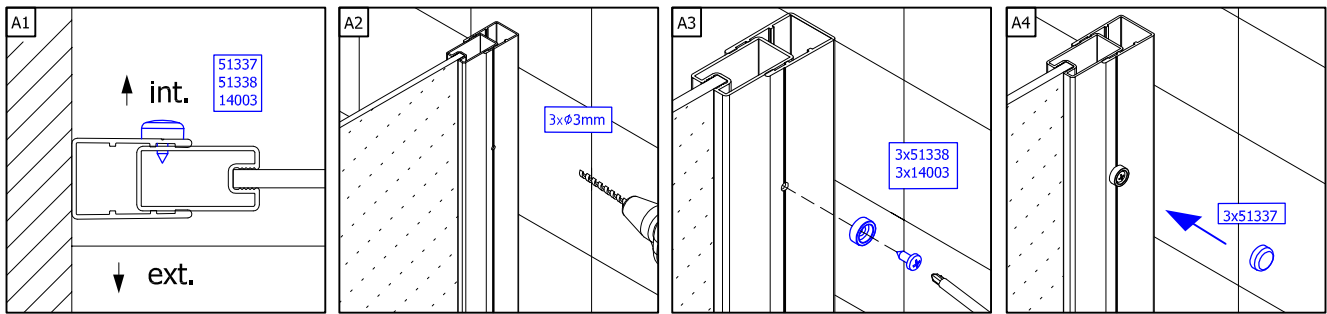
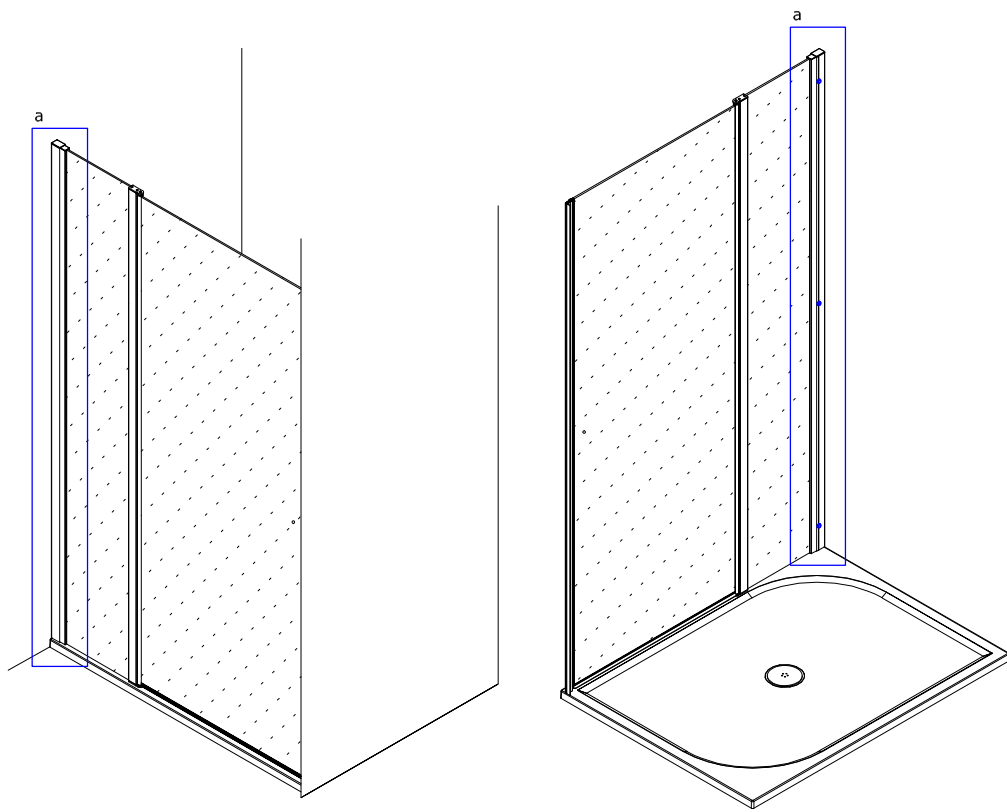

**17.**

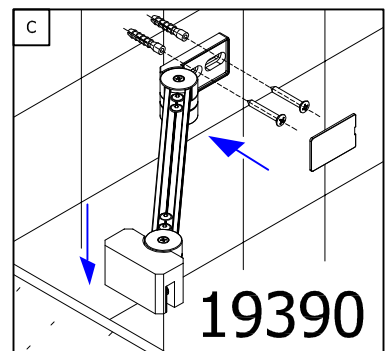
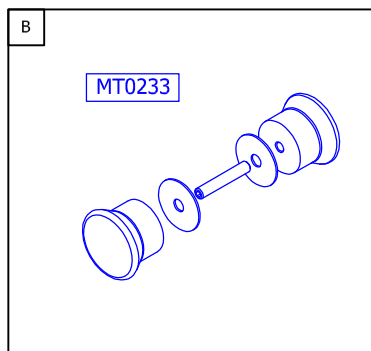
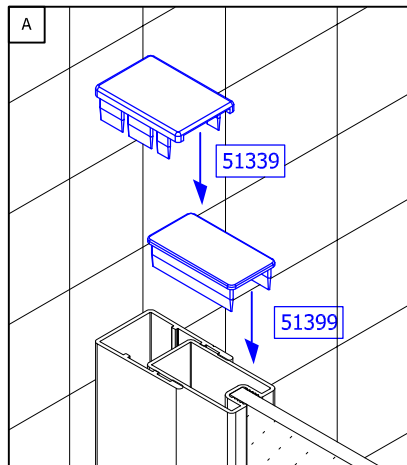
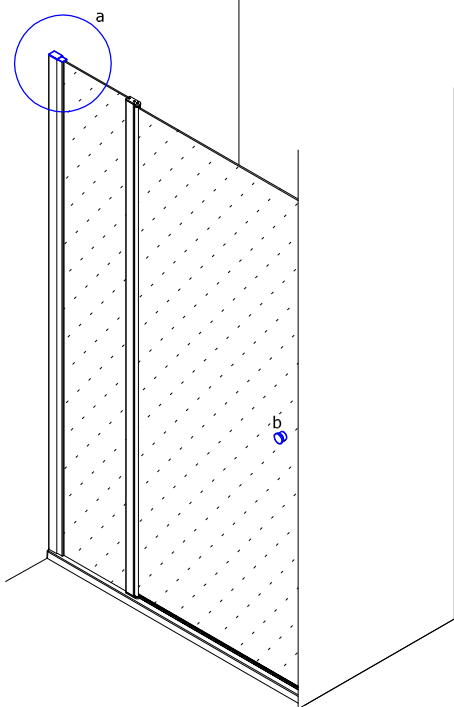

18.

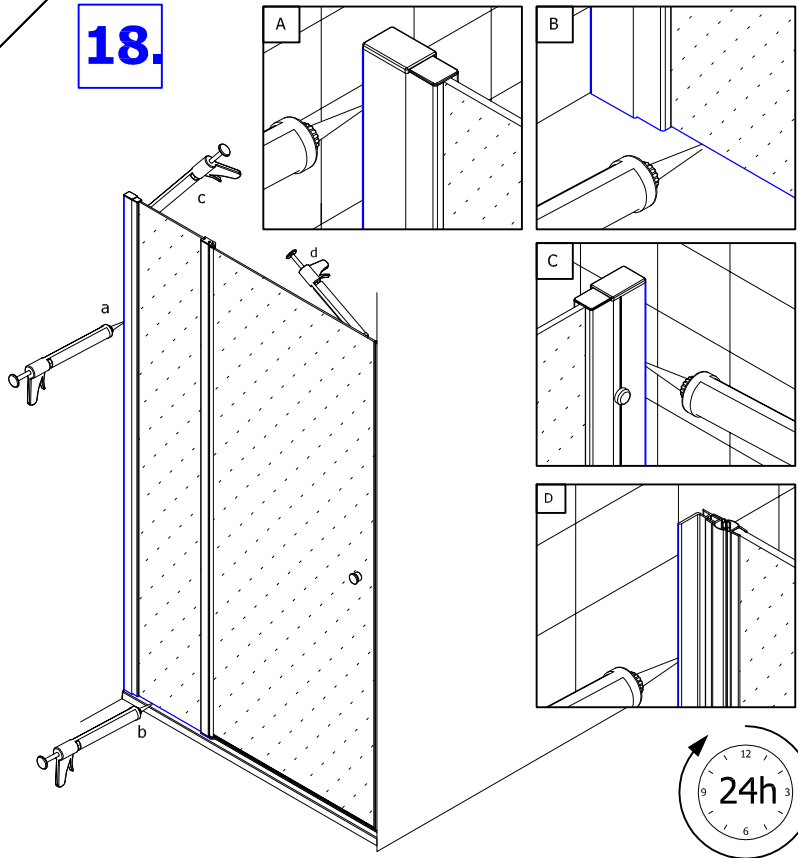

**Achtung!** Nur Sanitär-Silikon - bakterizid und fungizid eingestellt verwenden.

**Caution!** Use only bactericidal and fungicide sanitary silicone.

**Attention!** N'utiliser que du silicone sanitaire bactéricide et fongicide.

**Pozor!** Používejte pouze baktericidní a fungicidní sanitární silikon.

**Uwaga!** Stosować tylko sylikon sanitarny - bakterio i grzybobójczy.

**Pozor!** Уживайте только бактерицидный и фунгицидный санитарный силикон.

**Внимание!** Применять только антибактериальные силиконовые герметики с фунгицидом

**Cuidado!** Utilizar solamente silicona sanitaria bactericida y fungicida.

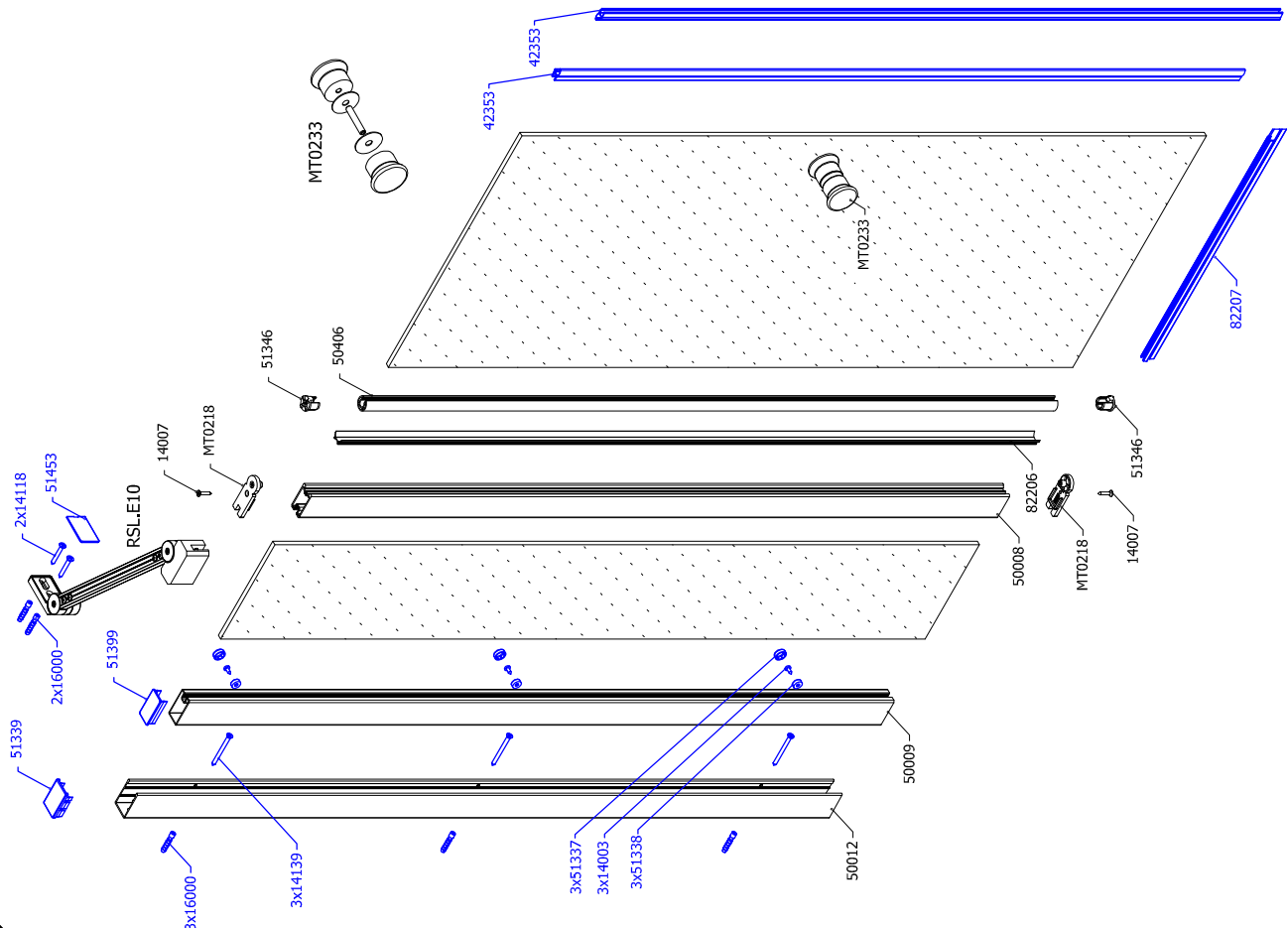
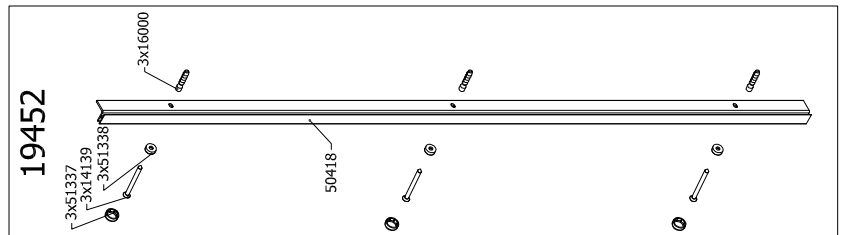
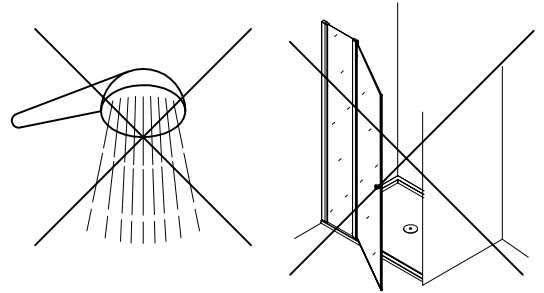

## QUALITY CONTROL:

- D** Dieses Produkt wurde unter sorgfältiger Beachtung der Qualitäts-Richtlinien gefertigt und vor dem Verpacken einer eingehenden Prüfung unterzogen. Sollten Sie dennoch einen Produktmangel oder eine Beschädigung feststellen, so setzen Sie sich bitte direkt mit der Firma in Verbindung, bei der Sie dieses Produkt gekauft haben.
- GB** This product was made with careful attention to quality guidelines and was subjected to a thorough examination before packaging. However, if you find a product defect or damage so please get in touch directly with the company in which you have bought this product.
- F** Ce produit est fabriqué avec une attention particulière selon des normes de qualité et est soumis à un contrôle approfondi avant l'emballage. Toutefois, si le produit présente un défaut ou un dommage, veuillez prendre contact avec l'entreprise qui vous a vendu ce produit.
- CZ** Tento produkt byl vyroben s odbornou péčí podle příslušných kvalitativních směrnic a před zabalením byl důkladně zkontrolován. Pokud u něho přesto zjistíte závadu nebo poškození, kontaktujte prosím firmu, u které jste výrobek zakoupili.
- PL** Produkt ten został wyprodukowany z uwzględnieniem rygorystycznych norm jakościowych, a następnie podany drobiazgowej kontroli przed zapakowaniem. Jeżeli po rozpakowaniu (przed rozpoczęciem montażu!) stwierdzicie Państwo wady lub uszkodzenia to prosimy o natychmiastowe zgłoszenie tego faktu sprzedawcy.
- SK** Tento produkt bol vyrobený s odbornou starostlivosťou podľa príslušných kvalitatívnych smerníc a pred zabalením bol dôkladne skontrolovaný. Ak u neho aj napriek tomu zistíte závadu alebo poškodenie, kontaktujte prosím firmu, u ktorej ste výrobok zakúpili.
- RU** Это изделие было изготовлено с особым вниманием в соответствии с высокими стандартами качества и было тщательно проверено перед упаковкой. В то же время, если вы обнаружите дефект или повреждение, обратитесь в компанию, у которой вы купили это изделие.
- E** Este producto ha sido fabricado cumpliendo estrictamente las normativas de calidad y ha sido sometido a un control exhaustivo antes de embalarlo. En caso de que a pesar de ello, Usted note algún desperfecto del producto, rogamos se ponga en contacto directamente con la empresa donde haya comprado el producto.
- RO** Acest produs a fost fabricat respectând cele mai stricte norme de calitate, iar produsul a fost testat înainte de a fi împachetat. Dacă totuși observați o neregulă sau o defecțiune, vă rugăm să contactați direct firma de la care ați achiziționat produsul.

.....

.....

.....

.....

.....

.....